



THE FINEST IN MUSICAL ENGINEERING



THE FINEST IN MUSICAL ENGINEERING

For all enquiries contact Burns® London Limited
Tel: +44(0)20 8783 3638
Fax: +44(0)20 8783 3651
sales@burnsguitars.com
WWW.BURNSGUITARS.COM

PLEASE NOTE: Specifications, hardware distributor and colours may be subject to change. Please check Burns® website for current specifications. Some of the guitars represented have been adapted to better illustrate current specifications at the time of printing. All original copyrights acknowledged and sources sought. ©2010 Burns® London Limited. Brochure design Allan Martin. Contact: allanmartin1@mac.com

CUSTOM ELITE & CLUB SERIES

JAMES ORMSTON BURNS began making guitars in the early 60s and soon his innovative designs were being used by all the influential musicians of the day.

These included: Hank Marvin, Elvis Presley, George Harrison, Marc Bolan, Jimmy Page, Mark Knopfler, Brian May, Tom Petty, Status Quo and Slade – to name but a few.

Burns designs were always ahead of their time and Jim's ideas have now become standard with many other guitar makers. These include the heel-less glued-in neck, the 24 fret fingerboard, knife-edge bearing vibrato units, active electronics and stacked-coil pickups.

In 1992 the Burns London company was re-established to manufacture authentic reproductions of the original and now very desirable guitars. The designs chosen for the re-issues represent the very best of the original guitars and have been painstakingly reproduced.

Many of the components have had to be purpose made and sourced – often from the same suppliers who made components for the original guitars.

However technology now allows us to make guitars that are more accurate and better finished. Body and neck timbers are far superior whilst the hardware has improved measurably both in quality and performance.

There's never been a better time to buy a Burns guitar. With new and limited editions being introduced regularly, you'll find one that's made for you.

Some of the musicians who have played Burns® guitars past and present...

Andy Powell • Beck	John Jorgenson
Andy Bell • Oasis	• Elton John Band
Animals	John Mayall
Badly Drawn Boy	John Paul Jones
Bert Weedon	Johnny Kidd & The Pirates
Billy Bragg	Johnny Hilland
Boz • Morrissey	Jimmy Page
Chris Stein • Blondie	• Led Zeppelin
Colin Burns • Ash	Justin Hawkins
The Coral	• The Darkness
Damon Johnson	Kaiser Chiefs
• Alice Cooper Band	The Kooks
Earl Slick	Lily Allen (Band)
• David Bowie Band	Nick Kane • Mavericks
Mark Knopfler	New Seekers
• Dire Straights	Brian May • Queen
Eddie Duffy	Phil Solem • Rembrandts
• Simple Minds	Ry Cooder
Edwyn Collins	Ray Russell
Elvis Presley	• The Searchers
Eric Clapton	Richard Wynn
Alex Kapranos	Robyn Bright
• Franz Ferdinand	Hank Marvin
Gaz Coombes	• The Shadows
• Supergrass	Bruce Welch
Graham Coxon	• The Shadows
Graham *****	Slade
• Madness & Seven T Band	Steve Marriot
George Harrison	• Small Faces
• Beatles	Status Quo
Henry Darnall	Mark Bolan • T Rex
• Young Knives	Andy McLaine • Texas
Honeycombs	Three Two One
Ike Isaacs	Toby McFarlane
Saul Davies • James	Tom Petty
Jeff Lynne	Tornadoes
Ian Anderson	Tremeloes
• Jethro Tull	Troggs
Jets	Unit 4+2
Joe Walsh • Eagles	The Who
John Farnar	We Should Be Dead
	Steve Howe • Yes
	Sting
	David McCabe • Zutons

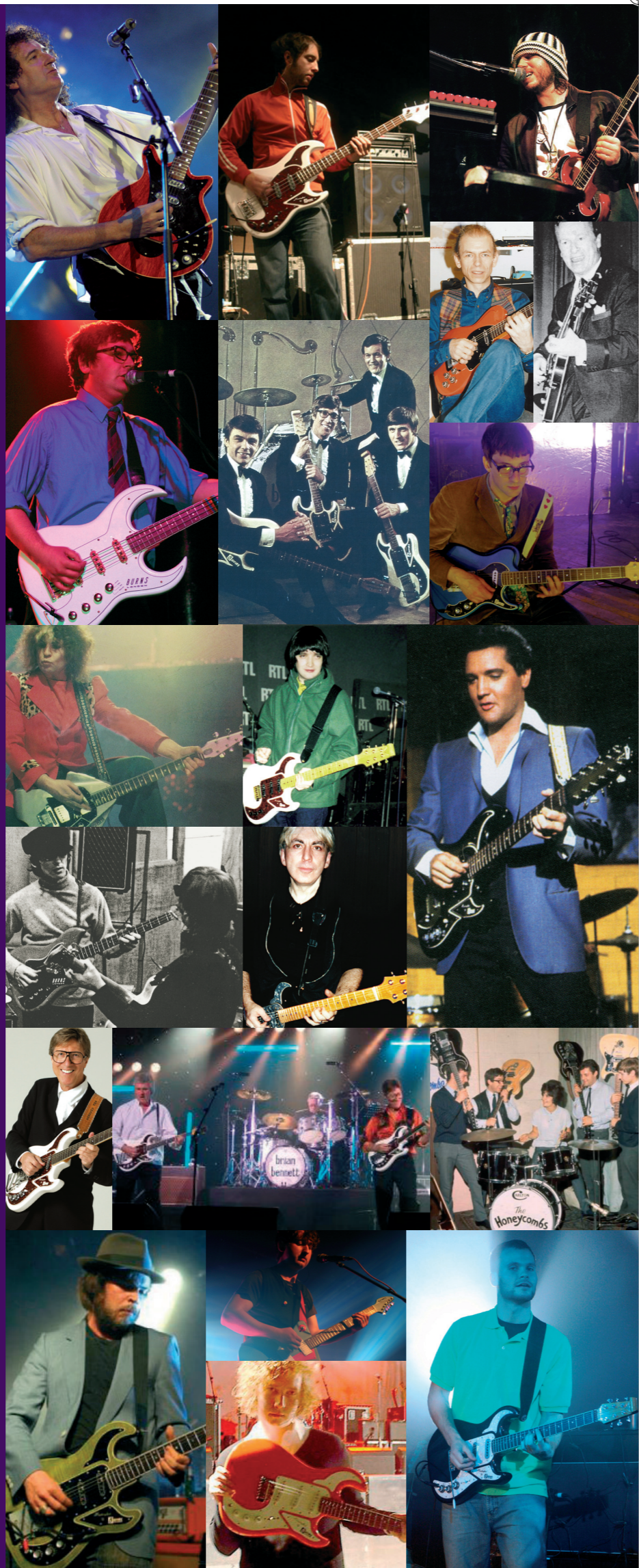

Contents



NEW DEVELOPMENTS & UNIQUE FEATURES

This new ENR Noiseless Rez-o-Matik® pickup is now fitted to the new Apache Special and Dream Noiseless models



Burns® Rez-o-Matik® ENR (Entwistle Noise Reduction).

Developed by Alan Entwistle (pictured) over the last ten years but not released until this year when Alan was finally happy he had developed a pickup that truly captured the unique single coil tone structure characteristic of the Rez-o-Matik®.

The Rez-o-Matik® ENR is uniquely different to other noiseless single coil systems, as it is actually developed from a full size Rez-o-Matik® single coil, using the same magnets and winding as the original.

Burns® Gear-o-Matik® Gearbox



This Burns® gearbox was first designed by Jim Burns in 1960 to allow fine neck setting. Coupled to the steel truss rod tensioned through the neck to a gearbox with a hefty cog and worm which provides micro adjustment

Club and Custom Elite Series Case

Each guitar comes with its own hard case and tool kit except for the Cobra which comes with it's own gig bag.



Custom Elite Series Accessories include:

- Burns® black leather strap
- Burns® leather pouch containing tool kit
- Burns® cleaning cloth
- Instruction manual
- Warranty card
- Tags

New pickup fitted to the Marvin and Bison 64 models

The new Burns® Rez-o-Matik® single coils are now made by Entwistle electronics, it has been recently discovered that the original 1964 Burns® Rez-o-Matiks® had an unusual winding pattern that in combination with the Rez-o-Tube® bridge, gave the Marvin and Bison 64 their unique sound.

Burns® Tri-Sonic® pickups fitted to Bison, Bison Bass, Marquee Bass, Double Six, Double Six Apache, Barracuda, Shadow

The Burns® Tri-Sonic® pickup stands alone in delivering it's famous 'singing' tone, and this achievement was no accident when the pickup was designed back in 1960 by Jim Burns and his team, in fact it is testament to just how far thinking these guys were.

The secret of the Tri-Sonic® lies in its magnetic circuit, which is designed to actually fold around the pickups coil, resulting in a fuller, wider frequency, harmonically rich tonescape.

New Mini Tri-Sonic® pickup fitted to the new Cobra

The new Mini Tri-Sonic® pickup delivers the same power and tone as the original larger Tri-Sonic®. Adrian Turner, of Adeson, developed a unique slimline version of the original 1960's Tri-Sonic® pickup – crafted and engineered for a standard more traditional S/S/S pickguard configuration, utilising all the original style build methods with scaled-down base-plates and compensated chromed brass covers.

New Burns® Rez-o-Tone™ fitted to the Bison 64

This is a five way rotary tone selector that preselects and filters various frequencies from any of the pickups combinations, it is not a tone control in the normal sense of the word, as all the selections are useful reflections of various vintage sounds, and acoustic textures.

The Burns® Rez-o-Tone™ was developed and manufactured by Entwistle Electronics, and is fitted to the current Bison 64 Rez-o-Tube® model.

How we choose our timbers

We believe it's important to source our commercial hardwoods from areas of guaranteed reforestation and natural regeneration.

The annual hardwood growth in Britain currently exceeds the volume of hardwood harvested and we buy all our native sycamore and beech from sawmills supporting the Timber Trades Federation (TTF) Forests Forever Campaign.

All our exotic hardwoods come from sawmills supporting the International Tropical Timber Organisation (ITTO).

This means you can be sure that every Burns® guitar is made from only prime quality ecologically sustainable woods.

MARQUEE

The Marquee guitar was developed as a budget version of the successful Custom series Hank Marvin Guitar, keeping as many of the original features as possible.

This guitar has won high praise in the European press and was awarded Guitar of the Year in 1999 and 2000.

It is by far the best-selling guitar in the Club series.

- Scroll headstock
- Burns® designed machine heads
- 43mm nut width
- Bolt-on hardrock maple neck
- Alder or basswood body
- Rosewood or maple fingerboard
- Scale length 25.5"
- 22 frets
- Bi-flex two-way type truss rod
- Three Burns® Alnico Rez-o-Matic® pickups
- Classic polyester finish
- Burns® de-luxe tremolo unit
- Five-way selector switch
- One master volume
- Two tone controls
- Push/pull pickup selector
- Chrome hardware as standard
- Please note: Gold hardware is no longer available on the Marquee



DAVID MCCABE
• ZUTONS

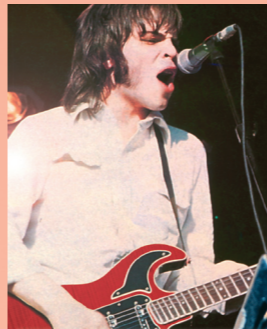

GAZ COOMBES
• SUPERGRASS

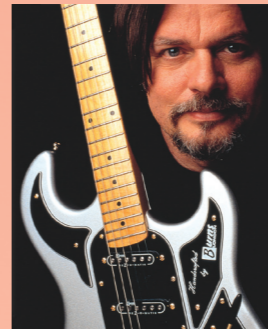

NICK CAVE
• MAVERICKS

Guitar magazine... "Hard to put down"

Total Guitar magazine... "Fantastic sound"

Guitarist magazine... "Classy looks! Great value for money, gold plating adds a touch of class"

Guitarist magazine... "Bargain of the century"

Guitar magazine... "Bargain of the year... or anytime"

MARQUEE PRO

MARQUEE BASS

Is a short scale Bass 32 inch. A re-issue of the original 1964 Jazz Bass, it features three Tri-Sonic® bass pickups and has the same versatile controls as the Marquee Guitar to give a wide range of superb bass tones.

Additional features for Marquee Bass

- Flat original headstock
- Burns® de-luxe machine heads
- Basswood body
- 40mm nut width
- Rosewood fingerboard
- Scale length 32"
- 20 frets
- Burns® de-luxe bridge
- Chrome hardware as standard
- Three Burns® Tri-Sonic® bass pickups
- Push/pull pickup selector

- Scroll headstock
- Burns® designed machine heads
- 43mm nut width
- Bolt-on hardrock maple neck
- Alder or basswood body
- Rosewood or maple fingerboard
- Scale length 25.5"
- 22 frets
- Burns® gearbox truss rod
- Three Burns® Tri-Sonic® pickups
- Classic polyester finish
- Tremolo unit
- Five-way selector switch
- One master volume
- Two tone controls
- Push/pull pickup selector
- Chrome hardware as standard



Total Guitar magazine...
"Star buy"

2 Available in: Shadows White; Green Burst; Guards Red

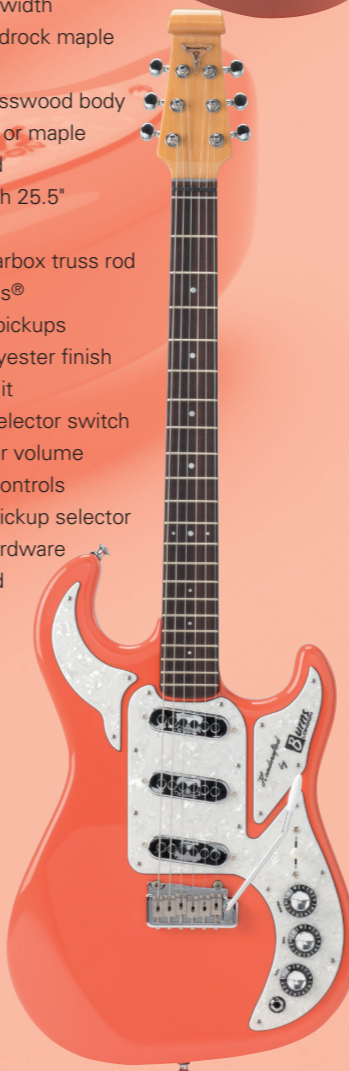

Available in: Guards Red; Jet Black

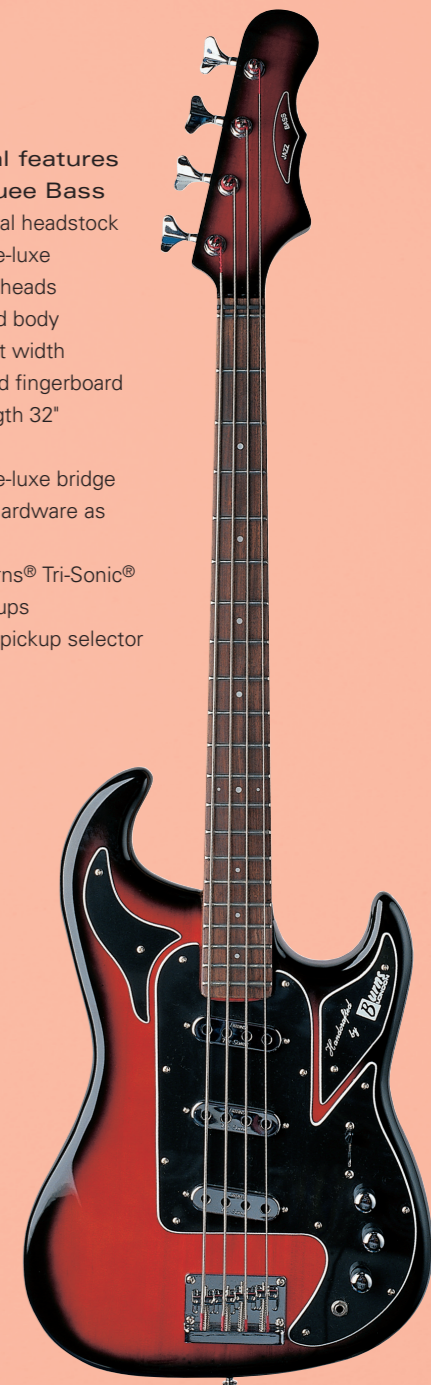

Available in: Shadows White; Baby Blue; Red Burst

A custom version of the classic Marquee model, with additional features including Pearloid neck binding, colour matched headstock and body, high grade fingerboard and three Tri-Sonic® pickups. Also fitted are Grover locking machine heads.

With gold hardware as standard, the Shadow has the same versatile controls as the Marquee guitar, giving a wide range of superb tones.

SHADOW SPECIAL

SHADOW



- Scroll-type original headstock
- Locking machine heads
- 43mm nut width
- Bolt-on hardrock Maple neck
- Rosewood fingerboard
- Scale length 25.5" with 22 frets

- Bi-flex two-way type truss rod
- Three Burns® Tri-Sonic® pickups
- Five-way pickup selector switch
- One master volume
- One master tone control
- Bridge pickup tone control and push/pull pickup selector
- Burns® de-luxe knife edge tremolo unit
- Pearloid binding
- Classic polyester finish
- Basswood body

• All Shadow Special and Shadow guitars are fitted with Burns® Tri-Sonic® pickups

Shadow Special available in: Honey Burst on Flame Top

Shadow available in: Black; Red Burst

Many companies produced a similar guitar to this model in the late fifties to early sixties, most famously were Guyatone and Antoria and Burns Weill.

Our Drifter LG 50 is a close replica to the Guyatone as used by Hank Marvin in the late fifties before he discovered Fender® and Burns® Guitars.

DRIFTER LG 50



- Basswood body
- Figured maple top
- Maple neck with Rosewood fingerboard
- 24 & three quarters scale
- 2 x Tri-Sonic® style pickups
- 1 x Master volume
- 1 x Master tone
- 3 way pickup selector switch

6 Available in: Natural finish only

The Barracuda can be played either as a short scale bass or an effective lead and rhythm guitar. Tuning is the same as a standard six string guitar but one octave below. As used by Jet Harris of the Shadows.

BARRACUDA
SPECIAL

BARRACUDA

BARRACUDA

SIX STRING BASS BARITONE GUITAR



- New feature: fitted with Burns® Rez-o-Tube® tremolo system

Guitarist & Bassist Magazine...

"One of the most amazing sounds ever produced"

Available in: Guards Red

- Basswood body
- Bolt-on hardrock Maple neck
- Burns® original headstock
- Classic polyester finish
- Rosewood fingerboard
- Scale Length 30"
- Nut Width 45mm
- Bi-flex two way type truss rod
- Ghotto fixed bridge unit
- 23 frets
- Chrome hardware as standard
- Burns® de-luxe machine heads
- Three Burns® Tri-Sonic® pickups
- Five way pickup switch
- Push/pull pickup selector
- One master volume
- Two tone controls
- The bridge unit is subject to change. A new model is in development as this brochure goes to press.

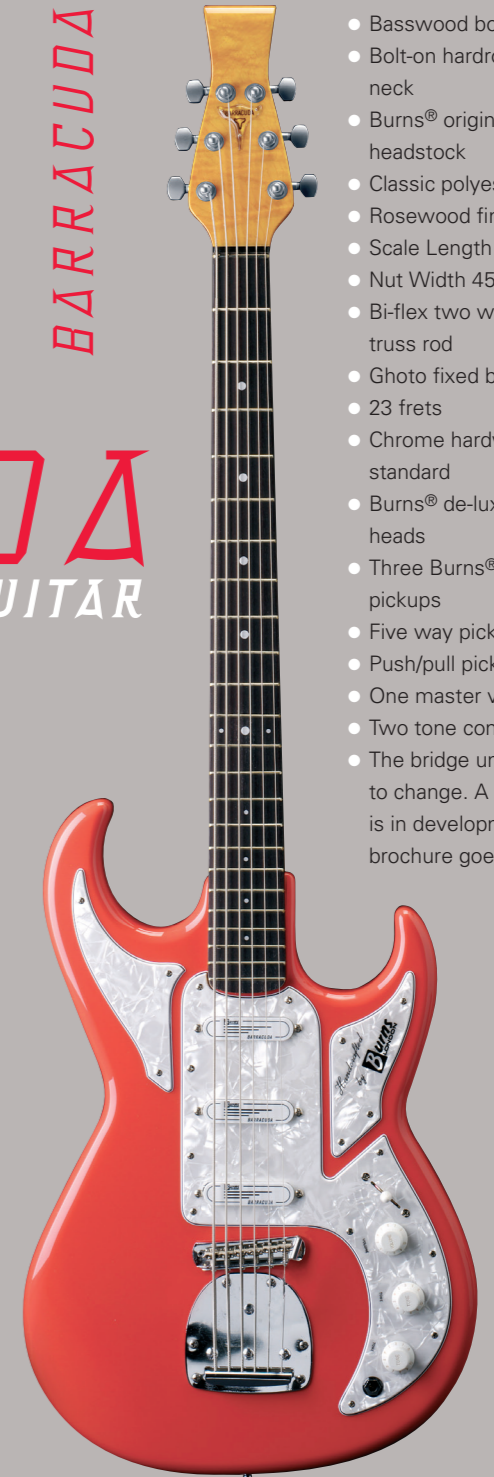

JET HARRIS

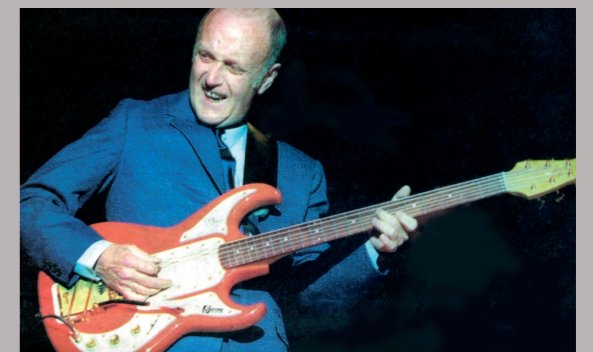

BISON 62

A re-issue of the 1962 Bison guitar, celebrating the 40th anniversary of the classic Burns® body shape with its inward curved body horns and advanced pickup selection system.

With its distinctive batwing headstock, this guitar was Jim Burns' greatest creation and this re-issue retains its strong look, sound and character. Already the recipient of great praise from the music media, it has a punchy vintage tone but delivers great modern sounds with its unique Wild Dog and Split Sound settings.

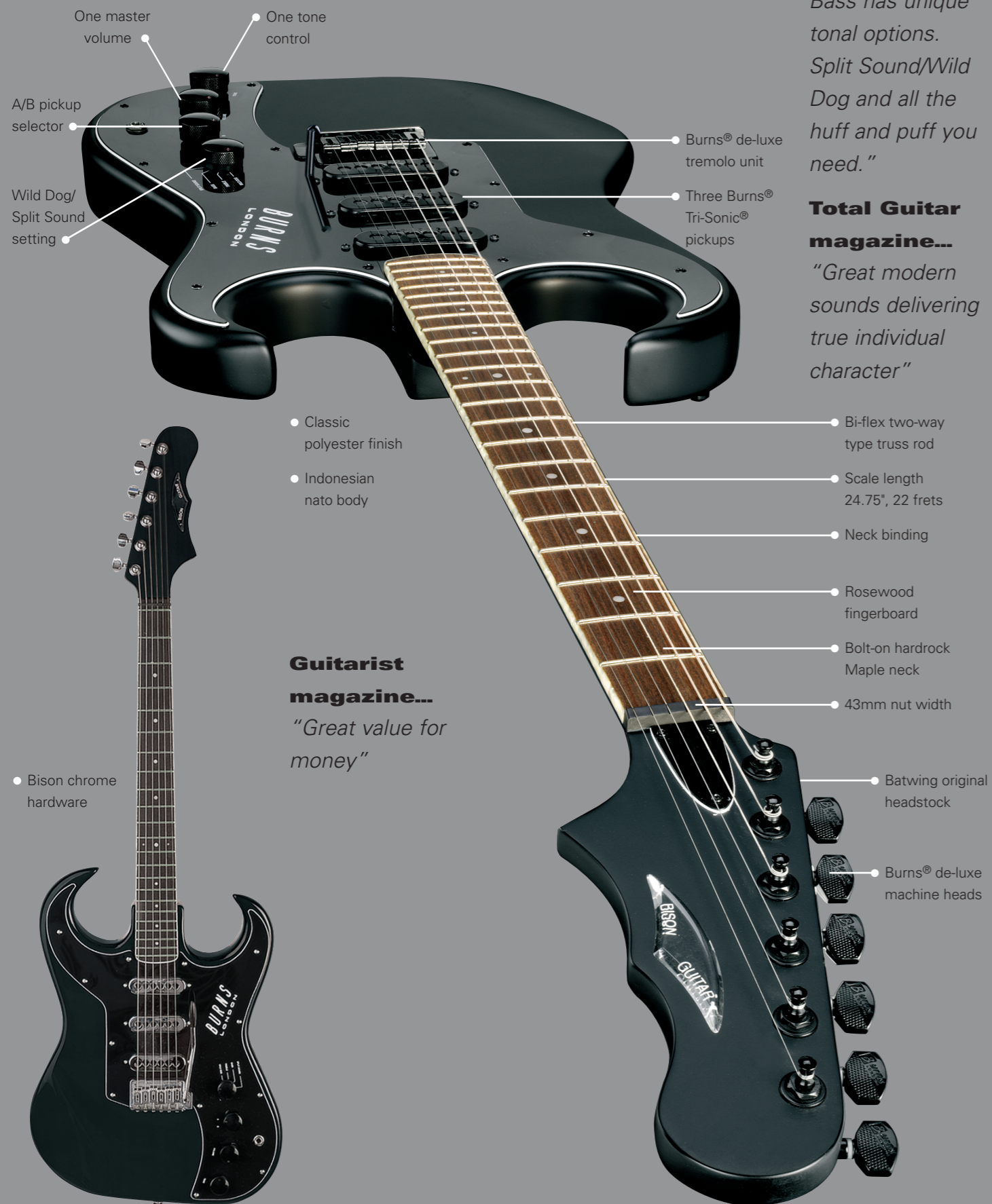

Guitarist Buyer magazine...

"Burns is going strong in its 50th year, the Bison Bass has unique tonal options. Split Sound/Wild Dog and all the huff and puff you need."

Total Guitar magazine...
"Great modern sounds delivering true individual character"

Guitarist magazine...

"Great value for money"

- Bison chrome hardware

8 Available in: Shadows White; Red; Jet Black

BISON 64



Additional features for Bison 64

- Scale length: 25.5"
- Basswood body
- Burns® Rez-o-tube® tremolo system
- Maple neck
- Rosewood fingerboard
- 3 piece laminated scratchplates
- Polyester finish
- 3 Alnico Burns® Rez-o-matik® pickups
- Chrome hardware as standard



BRIAN MAY WITH WHITE BISON



HENRY DARTNALL • YOUNG KNIVES

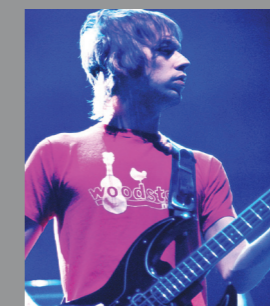

ANDY BELL • OASIS

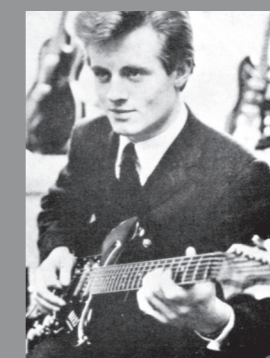

JOHN PAUL JONES • LED ZEPPELIN

Guitarist & Bassist magazine...

"A fantastic long scale beast of a bass, great in the Sixties – even greater now."

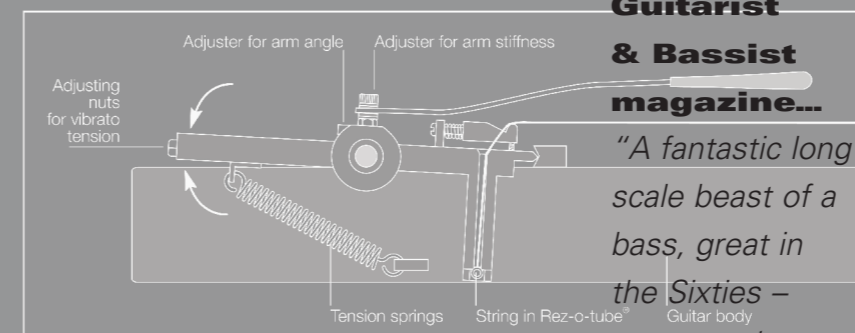

Available in: Shadows White; Jet Black

A RE-ISSUE OF THE 1961 BISON BASS

A favourite among session musicians in the Sixties due to its long scale and wide variety on big tones.

With all the same features as the original, the new Bison Bass is now used by many modern bands for live work and recording.

It delivers great distinctive vintage tone not heard on its American counterparts. The **Wild Dog** and **Split Sound** settings are unbelievable!



Additional features for Bison Bass

- Scale length 34"
- Nut width 40mm
- Burns® de-luxe bridge unit
- 22 frets
- Chrome hardware
- Burns® de-luxe machine heads

Available in: Shadows White; Jet Black

9

COBRA

The Cobra design originates from the popular Drifter Custom model with matching colour batwing style headstocks. It features the new Burns® knife edge tremolo system based on the original Rez-o-tube® pivot design, which is well known for its stability in returning to pitch. They also have the new low noise, Burns® Mini Tri-Sonic® single coil pickups. Standard features are the bi-directional truss rod and the push-pull tone control that gives increased pick-up selections.

The guitar is available with a rosewood fingerboard, split three-ply mint green scratchplates and a choice of body colours.

New Mini Tri-Sonic® Pickup



• All Cobra guitars are fitted with the new Mini Tri-Sonic® pickups as standard

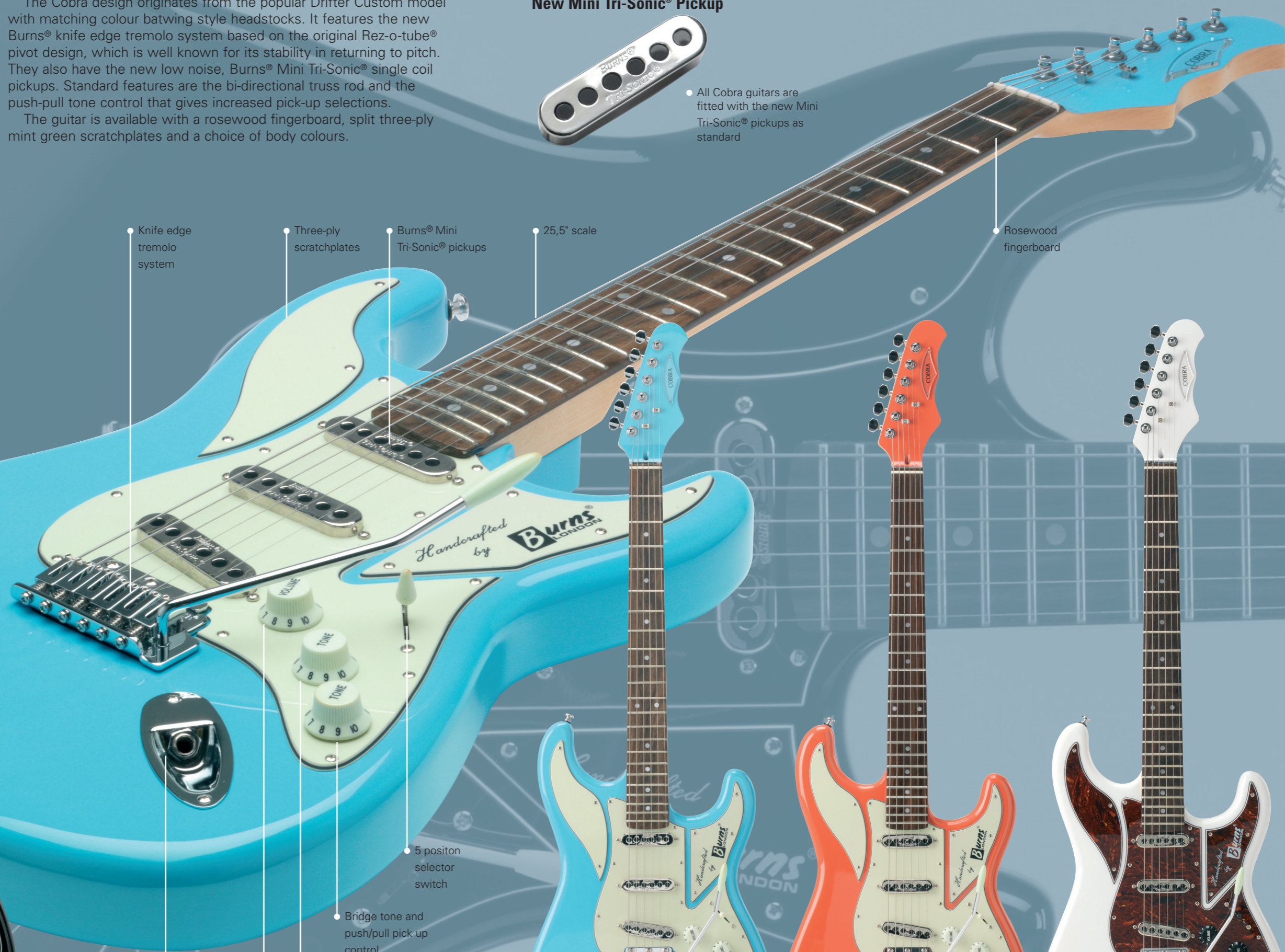

Knife edge tremolo system

Three-ply scratchplates

Burns® Mini Tri-Sonic® pickups

25.5" scale

Rosewood fingerboard

5 position selector switch

Bridge tone and push/pull pick up control

Front mounted jack socket

Neck and middle pickup tone control

Master Volume control



Available in: Jet Black, Shadows White; Baby Blue; Guards Red 11

STEER

A RE-ISSUE OF THE 1979 STEER GUITAR

The Steer was described in the USA Guitar magazine as a new guitar with bizarre beauty because of its original design and sound-hole feature – catching the eye immediately.

With two body cavities, the semi-hollow Steer delivers a wide range of awesome tones.

Its beefy sound comes from a Burns® split humbucking pickup at the bridge and its mellow neck pickup, designed especially for this instrument.

20 frets
25.5" length

43mm
nut width

Burns® de-luxe
machine heads

Bolt-on hardrock
Maple neck

Bi-flex two-way type
truss rod

Classic polyester finish
on basswood body

Burns® split
humbucking pickup

Burns®
Tri-Sonic® pickup

Three-way
pickup
selector
switch

Two separate
tone
controls

Burns® de-luxe
machine heads

Coil tap switch

Master volume, ideally
positioned for violining

The unique Burns®
original headstock has
extra guides for the
middle strings

Please note, the
fingerboard on the
Steer guitar will now be
available in Rosewood
only. The photographs
below have been
adapted to show this for
illustration purposes.



HENRY DARTNALL
• YOUNG KNIVES



PHIL SOLEM
• REMBRANTS



BILLY BRAGG

The single cutaway is
the only change from
the standard model,
allowing better access
to the high frets for solo
playing.

STEER GUITAR

STEER CUTAWAY

Available in: Green Burst

USA Guitar Player Magazine...

Editors Choice Award: "melt in your
hand playability and awesome tone..."

Guitar Buyer Magazine...

"All up, very cool indeed."

DOUBLE SIX

First introduced in 1963, the Double Six guitar is by far the most user friendly twelve string guitar on the market today.

The 55mm nut width allows ample room for the strings to be separated for easier fingering. The strings are fitted through a specially designed bridge, specially designed to achieve perfect intonation. It has seven different pickup selections.

DOUBLE SIX 12 STRING

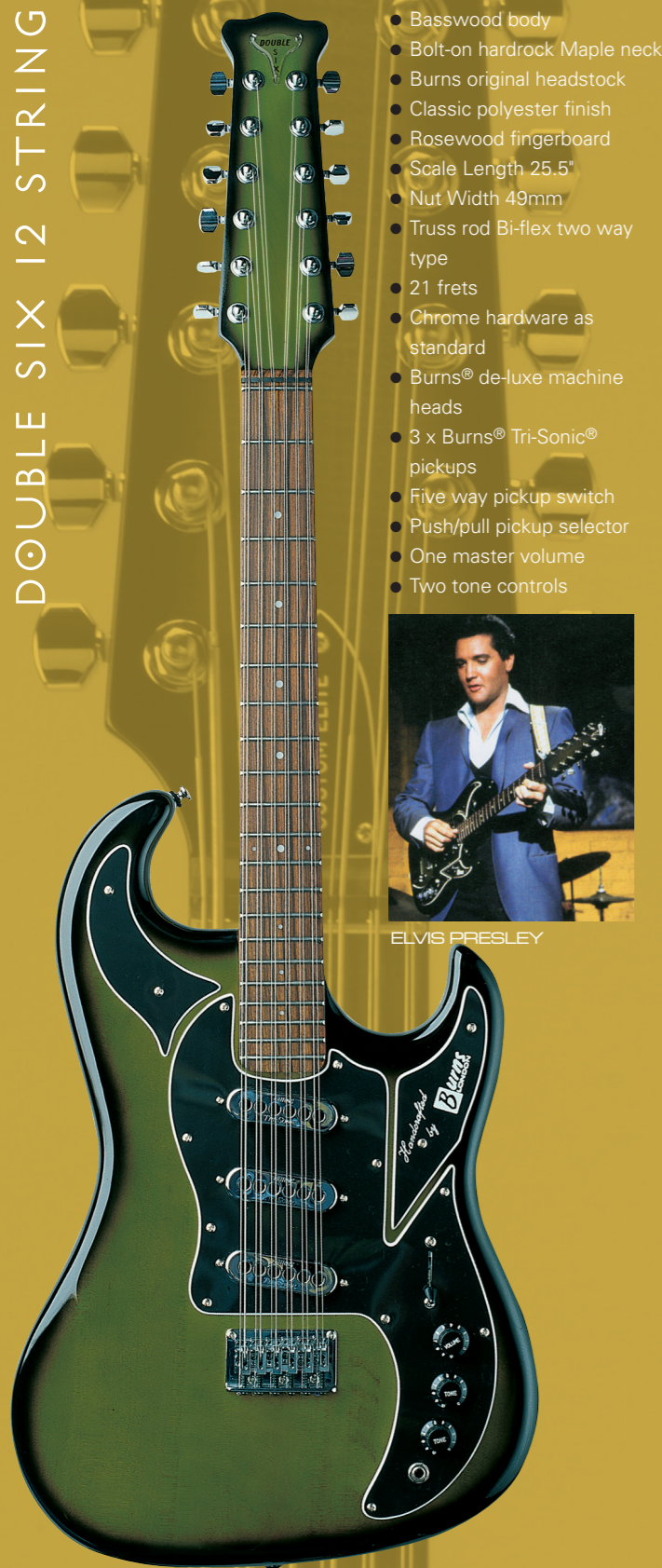

- Basswood body
- Bolt-on hardrock Maple neck
- Burns original headstock
- Classic polyester finish
- Rosewood fingerboard
- Scale Length 25.5"
- Nut Width 49mm
- Truss rod Bi-flex two way type
- 21 frets
- Chrome hardware as standard
- Burns® de-luxe machine heads
- 3 x Burns® Tri-Sonic® pickups
- Five way pickup switch
- Push/pull pickup selector
- One master volume
- Two tone controls



ELVIS PRESLEY

14 Available in: Green Burst; Red Burst



HANK MARVIN

DOUBLE SIX APACHE SPECIAL

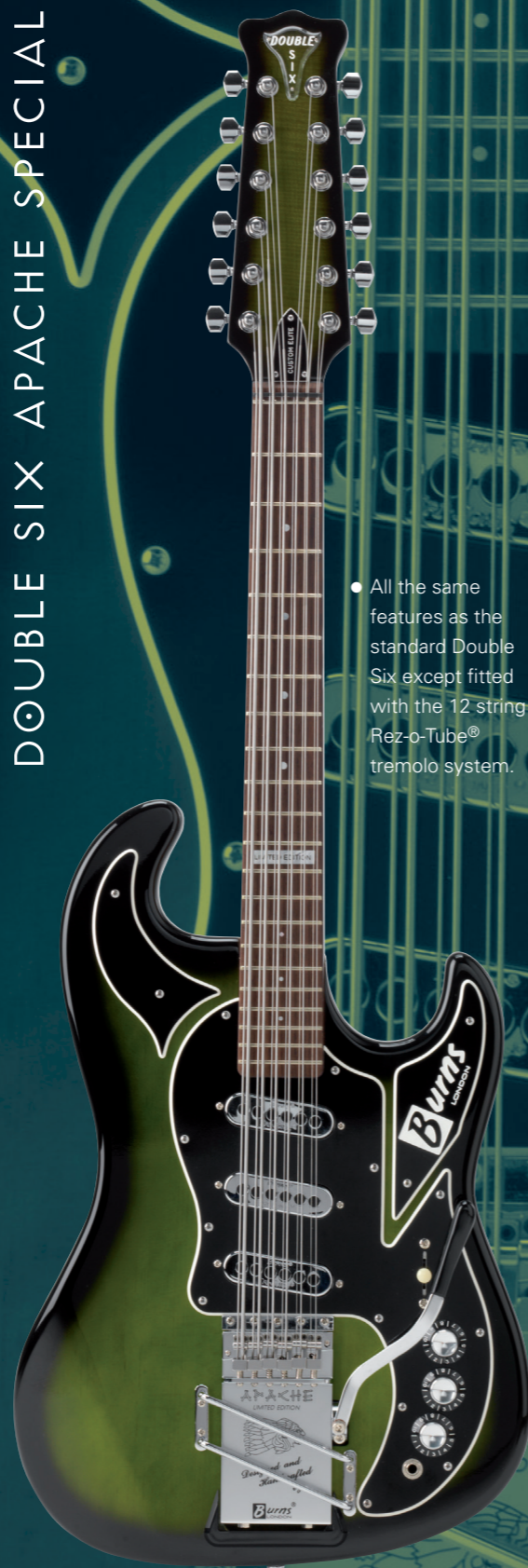

- All the same features as the standard Double Six except fitted with the 12 string Rez-o-Tube® tremolo system.

Available in: Green Burst

Sonic



- Nut width 43mm
- Scale length 25.5"
- Canadian Maple neck
- Fingerboard radius (compound 10 to 12 inches)
- Indian Rosewood fingerboard
- Fitted with 21 fast low profile frets
- Burns® Gear-o-Matik® Gearbox
- Burns® Gear-o-Matik® Truss Rod Gearbox
- Body made from Basswood
- 2 x Burns® Tri-Sonic® Pickups
- 1 x 3 Way Pickup selector switch
- 1 x Master Volume
- 1 x Master Tone
- Featuring Burns® unique Rez-o-Tube® bridge



GRAHAM COXON

Available in two colour themes: Sonic Blue with Black; Jet Black with Black

15



Burns Legend 1964

Hank Marvin says about the Burns Marvin 1964...

Some guitarists think of the USA as the only source of quality electric guitars, and for the most part they are correct. However, there are many of us who remember the superb range of guitars designed and made by Burns London, a British company.

Back in 1963, Jim Burns, the founder of the Company, worked closely with myself and Bruce Welch of The Shadows to design a guitar which would have the style, sound, and playability we required. Together we developed the 'Burns Marvin' a fine guitar, which I played on record, stage and screen from 1964 thru to 1970 when, unfortunately, my guitars were stolen, never to be seen again, well not by me!

I am delighted that Burns London are still in the business of making quality instruments, and in particular the new 'Burns Marvin'.

Playing this new 'Marvin' brings back a host of memories; such as the recording of 'The Rise and Fall of Flingel Bunt', together with many other Shadows tracks I recorded with my Burns.

The new 'Burns Legend' plays superbly and I am very happy to be the proud owner of one of these fine guitars, it plays and sounds as good as my original.

Hank B. Marvin



- Original style tuners
- Fitted with D'addario medium guage strings
- Neck made from Canadian hard rock Maple
- Body and neck finished in original polyester
- Body made from selected American Alder
- 3 Rez-o-Matic® pickups, handmade to original specifications with USA Alnico magnets
- Five-way pickup selector switch
- One master volume
- Two tone controls
- Push pull tone control, this feature adds two extra pickup combinations
- Rez-o-Tube® tremolo system made to exact specifications in highest quality lightweight duralumin
- Bridge saddles and tremelo arm made from stainless steel
- Palm Rest

- Fingerboard Indian Rosewood
- Tortoiseshell effect scratch plates

- Fingerboard Bound Maple



Available in three colour themes: Fiesta Red with white scratch plates; Shadows White with tortoiseshell scratch plates; Green Sunburst with black scratch plates

DREAM

NOISELESS • LIMITED EDITION



- Alder Body
- Figured Maple neck
- Pearl Binding
- Custom Figured Maple top
- Black Pick-guards
- 22 Frets
- Burns® Rez-o-Matik® Noiseless Pickups
- Gold hardware
- Burns® locking machine heads
- Locking strap nuts
- Hand signed and numbered certificate of authenticity
- Burns® Fitted case
- Leather Burns® Strap
- Leather tool kit
- Warranty card
- Burns® duster



18 Available in: Honey Burst; Red Burst; Blue Burst; Gold



PAT. APP. REG. DES.

APACHE

SPECIAL NOISELESS LIMITED EDITION

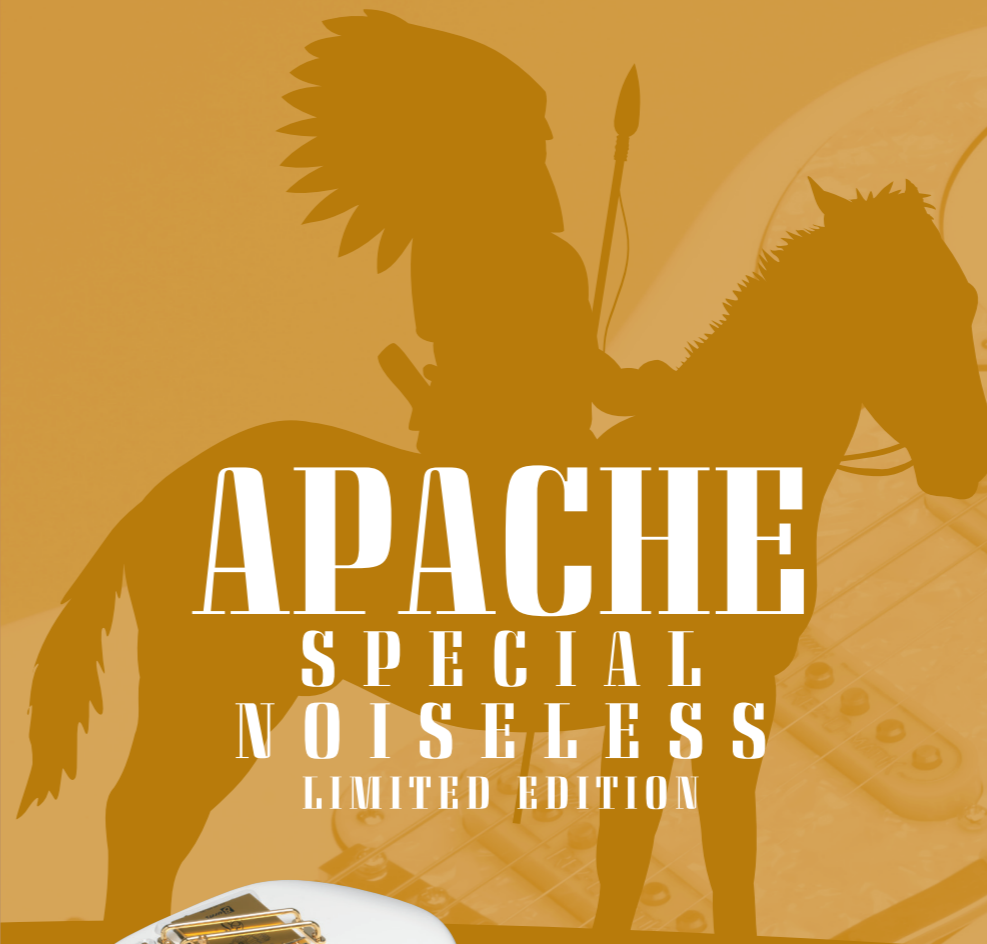

Available in: Shadows White; Transparent Red

- Alder Body finished in White Polyester
- 5 Star figured Maple neck with Ebony Fingerboard and Pearl Binding, the word Apache inlaid in mother or pearl in the 12th fret
- Pearl Pick-guards
- 22 Frets
- Burns® Rez-o-Matik® Noiseless Pickups
- Gold hardware
- Burns® locking machine heads
- Locking strap nuts
- Apache symbol engraved on the Rez-o-Tube® tremolo plate
- Burns® Fitted case
- Leather Burns® Strap
- Leather tool kit
- Warranty card
- Burns® duster



BURNS® SHADOWS BASS 1964

With the complete success of the Anniversary Marvin Signature Guitar we are now delighted to offer the long awaited matching Shadows bass guitar as a special edition.



This special instrument has been remade to the exact specifications from the original bass used by John Rostill of the Shadows.

Burns® London acquired the original Shadows bass in 2005 which inspired us to re-release this great guitar as a special edition.

Close research revealed this bass was quite different to the production model of 1964. The electrics are custom wired to give a wider range of pickup selections. As well as various cosmetic changes including headstock size, pickup spacing and selector switch angle.

In 1964 a bar type bridge was fitted to all Burns® basses. To improve tuning and intonation we have used four separate bridge saddles while retaining the original Burns Rez-o-Tube® bridge unit.



- Original Van Gent type black button machine heads
- Nut width 44mm
- Scale length 33.5"
- Neck made from Canadian Hard Rock Maple
- Fingerboard made from Indian Rosewood
- Burns® Gear-o-Matik® Truss Rod Gearbox
- Original Brown Tortoiseshell Cellulose Scratch-plates are fitted to match the Marvin guitar
- Body made from American Alder
- Polyester finish
- Featuring Burns® unique Rez-o-Tube® aluminium bridge unit
- 3 x original Nu-Sonic® type pickups
- Chrome palm rest
- Master Volume
- 5 Way Pickup selector switch
- Tone control for neck and middle pickup
- Separate tone cut for bridge pickup
- Push/pull tone pot for two extra pickup combinations

Available in: Shadows White; Green Burst



COLOURS



SHADOWS WHITE

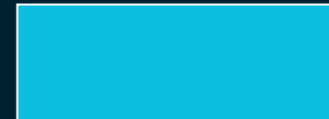

BABY BLUE



SONIC BLUE



HONEY BURST



FIESTA RED



GUARDS RED



TRANSLUCENT RED



RED BURST



3-TONE SUNBURST



GREEN BURST



BLUE BURST



GOLD



JET BLACK

Colour samples shown are only approximate due to the limitations of printing. Actual colour may vary on instruments depending on choice of timber.